



## Benjamin - 5.-6. klasse - 2022



### Opgave 3: Fodbolden



Australien

Team Bæver vil gerne lave en fodbold, der ligner den på billedet.



De har fire forskellige materialer at vælge imellem.

#### Spørgsmål:

Hvilket materiale kan de bruge til at lave fodbolden?

#### Svar:

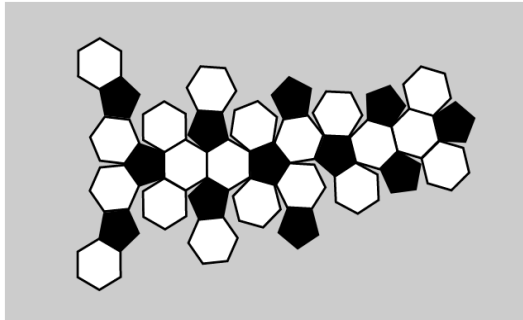
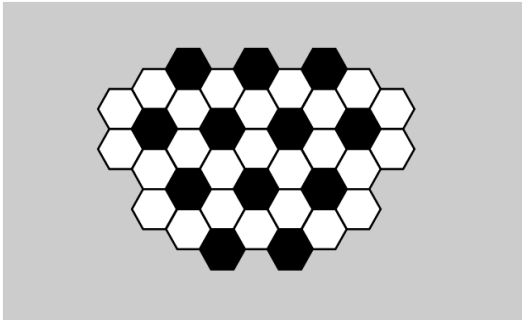
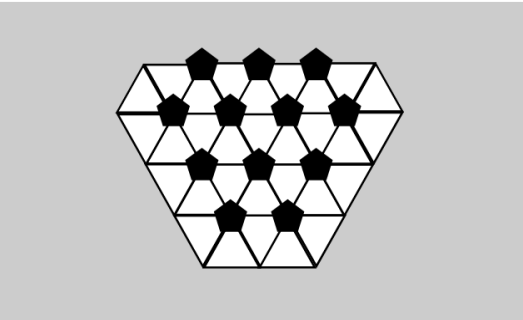
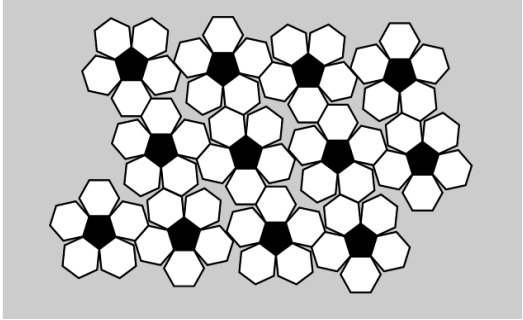
A	B
	
C	D
	





## Benjamin - 5.-6. klasse - 2022



### Opgave 2: Gættespillet



Schweiz

Julie og hendes venner leger en gættelej. For at starte spillet lægger Julie en kugle i taske A, en perle i taske B og et krøllet stykke papir i taske C. .





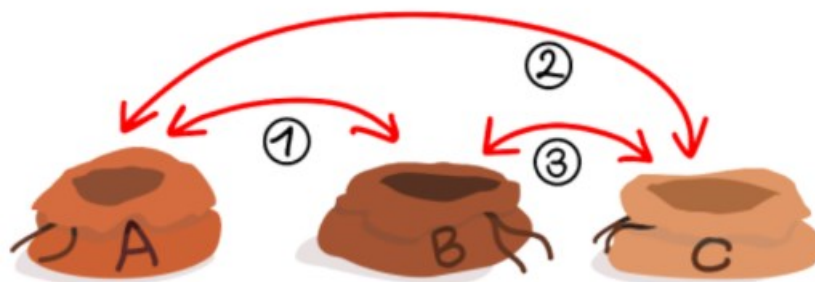





Bagefter beder Julie sine venner om at lukke øjnene. Mens deres øjne er lukkede, blander hun indholdet af taskerne sammen. Først ombytter hun tingene i taskerne A og B. Derefter ombytter hun tingene i taskerne A og C. Til sidst ombytter hun tingene i taskerne B og C.

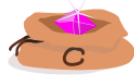

### Spørgsmål:

I hvilke tasker ligger Julies ting nu?

### Svar:

A			B			C		
								





## Benjamin - 5.-6. klasse - 2022



### Opgave 3: Bøger på biblioteket



Børn låner bøger på biblioteket. Biblioteket lavede et lånebord for at finde ud af, hvilken bog der var den mest populære.







### Spørgsmål:

Hvilken bog låner børnene oftest ud fra låneskemaet?

### Svar:

A	B	C	D
			





## Benjamin - 5.-6. klasse - 2022



### Opgave 4: Skildpadden og haren



Filippinerne

En skildpadde og en hare skal have et kapløb mod hinanden.

De starter begge samtidigt i cirklen med et hjerte i. De følger retningen med pile på banen.

Skildpadden bevæger sig en cirkel hvert minut.



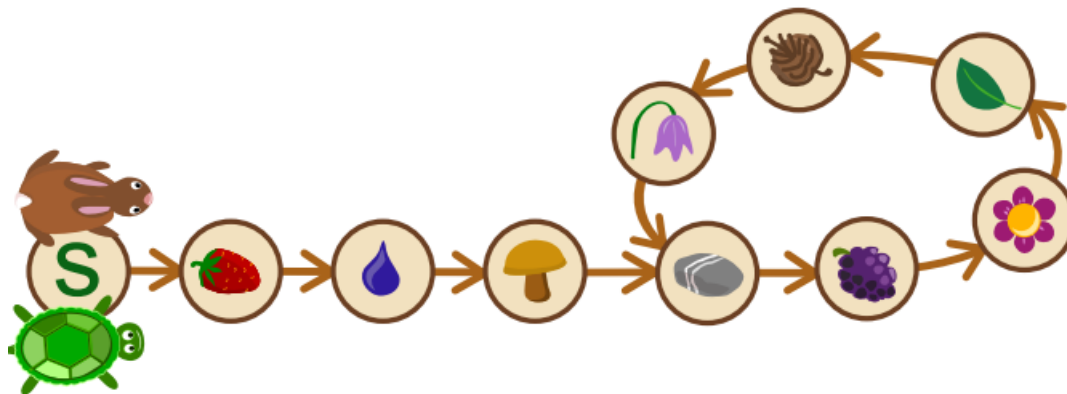





Haren bevæger sig to cirkler hvert minut.



### Spørgsmål:

I hvilken cirkel mødes skildpadden og haren for første gang i kapløbet?

### Svar:

A	B	C	D	E	F	G	H	I
								





## Benjamin - 5.-6. klasse - 2022



### Opgave 5: Bæveren på hotel



Indien

Bæveren vil flytte fra START-rummet til sit hotelværelse.

Bæveren bruger et kort over værelserne på hotellet.

På kortet er hvert værelse markeret med et billede.

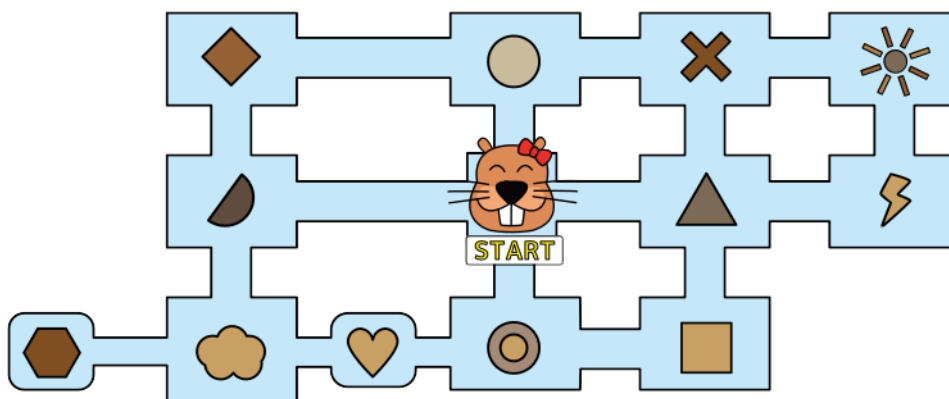



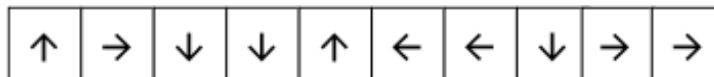









Bæveren bevæger sig efter denne ordre:



### Spørgsmål:

Hvilket hotelværelse er bæverens?

A	B	C	D	E	F	G	H	I	J	K	L
											





## Benjamin - 5.-6. klasse - 2022



### Opgave 6: Mikado



Brasilien

Anders spiller mikado. Hun taber nogle mikadopinde på et bord og samler dem op efter disse regler:

Man må kun tage ne pind op af gangen, og man må kun tage en pind op, hvis ingen anden pind ligger ovenpå den.

Eksempel:

Anders taber tre pinde på denne måde:

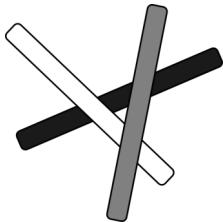

Anders må kun samle pindene op i denne rækkefølge

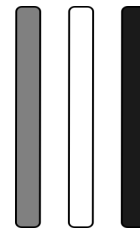

Anders taber 6 pinde på denne måde:

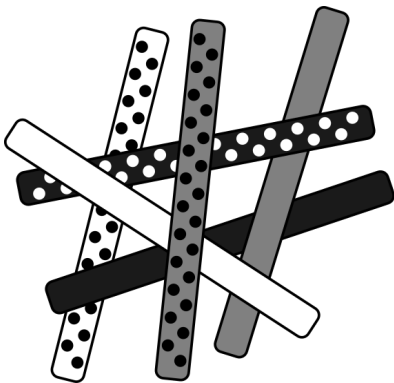

### Spørgsmål:

I hvilken rækkefølge skal Anders samle de 6 pinde op?

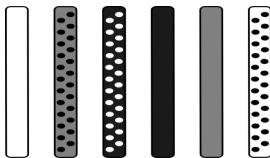
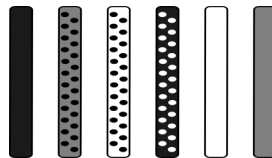
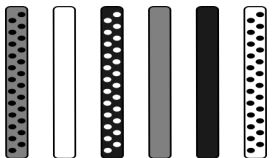
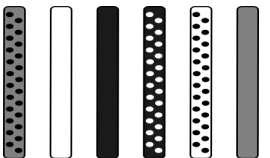
A	B	C	D
			





## Benjamin - 5.-6. klasse - 2022



### Opgave 7: Hjertegrafik



Ella har to figurer: En cirkel og et kvadrat. Hun designer et hjerte ud fra de to former.

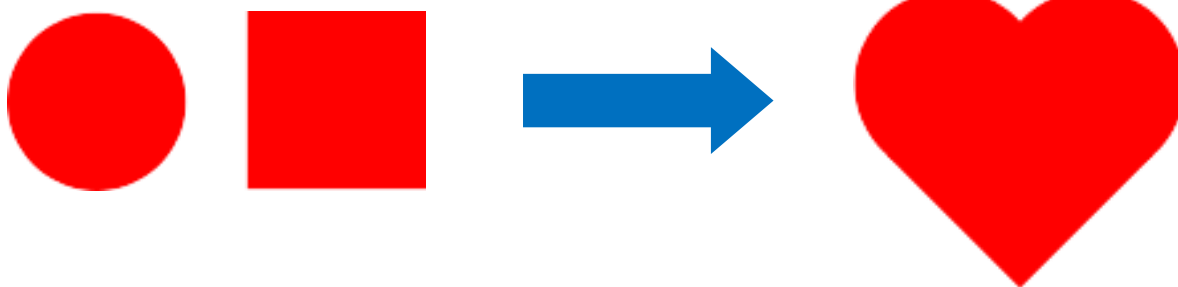

For at designe hjertet brugte Ella kun disse operationer på figurene:

- Rotation: Figuren kan drejes i begge retninger
- Flytning: Figuren kan flyttes et andet sted hen
- Duplikering: Figuren kan kopieres, så den bliver dobbelt på samme sted.

### Spørgsmål:

Hvilke operationer har Ella brugt for at design hjertet?

A	B	C	D
Dupliker cirkel.	Dupliker kvadrat.	Dupliker cirkel.	Flyt cirkel.
Roter kvadrat.	Roter kvadrat.	Roter cirkel.	Flyt cirkel.
Flyt cirkel.	Flyt kvadrat.	Flyt cirkel.	Dupliker cirkel.
Flyt cirkel.	Flyt cirkel.	Flyt kvadrat.	Flyt kvadrat.





## Benjamin - 5.-6. klasse - 2022



Sydkorea

### Opgave 8: Hamburgere

Kasper laver hamburgere efter disse regler:

1. Sauce er lige oven på kødet.
2. Kødet og osten er under agurker, salat og løg.
3. Løgene rører ikke bollehalvdelen.

#### Ingredienser:

Boller

Kød

Sauce

Agurker

Salat



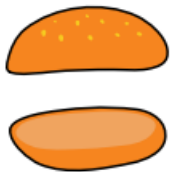

Løg

Ost



#### Spørgsmål:

Hvilken burger er har Kasper lavet rigtigt ud fra reglerne?

A	B	C	D
			







## Benjamin - 5.-6. klasse - 2022



Slovakiet





### Opgave 9: Broderimaskinen

Lone har en programmerbar broderimaskine derhjemme.

Maskinen kan brodere disse to sting:  

Når stoffet skubbes tilbage kan maskinen brodere oveni tidligere sting, så det færdige sting kan se sådan ud: 

Lone kan programmere broderimaskinen med disse tre knapper:

-  Maskinen vil brodere: 
-  Maskinen vil brodere: 
-  Maskinen vil rykke tilbage til sidste sting

Et program oprettes med knapperne og udføres gentagne gange med broderimaskinen.

Eksempel: Broderimaskinen laver dette mønster ud fra programmet:





































Programmet:     

Mønster:               

### Spørgsmål:

Hvilket program har Lone brugt til dette mønster:

<b>A</b>	          
<b>B</b>	      
<b>C</b>	        
<b>D</b>	         





## Benjamin - 5.-6. klasse - 2022



### Opgave 10: Sømandshalskæde



Slovakiet

Her er instruktioner til at lave en sømandshalskæde med bølgede rød-hvide perler og ensfarvede blå perler.

I en sømandshalskæde starter man med at placere en bølget perle og en blå perle på en snor i denne rækkefølge:

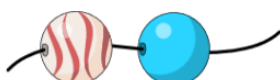

Sømandshalskæden kan derefter gøres længere på følgende måder:

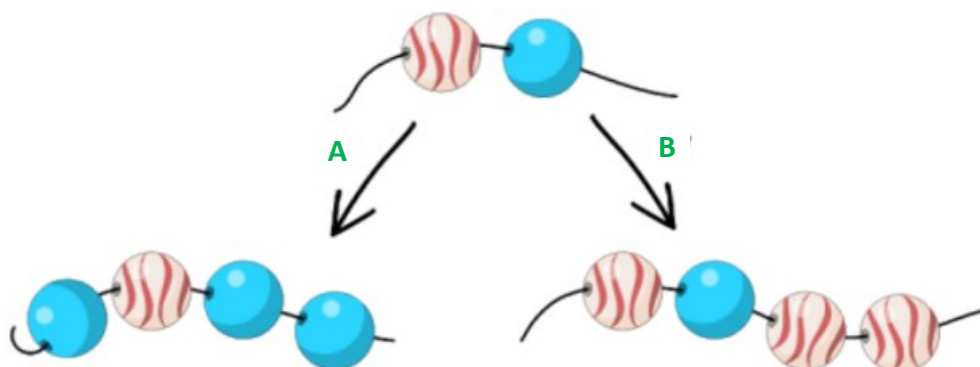

- Tilføjelse af en blå perle i begge ender af snoren (handling A).
- Tilføjelse af to bølgede perler længst til højre på snoren (handling B).



Disse handlinger kan gøres flere gange for at bygge længere og længere halskæder.

### Spørgsmål:

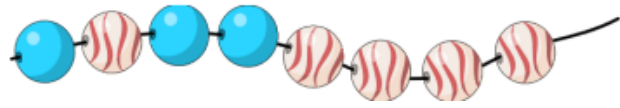
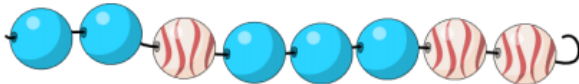
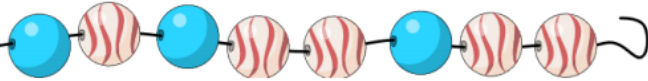
Hvilken halskæde er ikke en sømandshalskæde?

<b>A</b>	
<b>B</b>	
<b>C</b>	
<b>D</b>	





## Benjamin - 5.-6. klasse - 2022



### Opgave 11: Puslespil



Belgien

Ingrid skal samle fire brikker i et puslespil. De fire brikker skal samles i en 2 x 2 firkant efter følgende regel:

Brikkerne må kun røre hinanden på sider, som har præcis det samme symbol.

Eksempel:

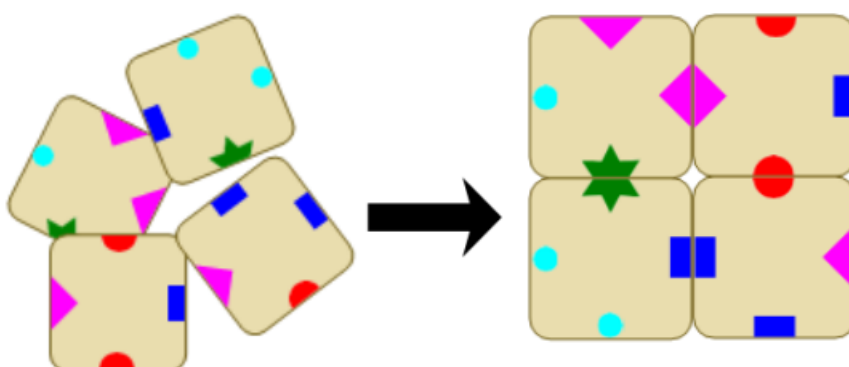

Ingrid har nu disse fem brikker:



Hun skal samle 4 af brikkerne i en 2 x 2 firkant efter reglen.

### Spørgsmål:

Hvilken brik kan ikke bruges, når reglen skal følges?

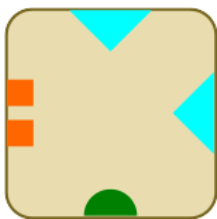
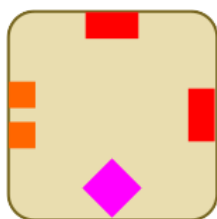
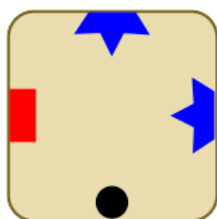
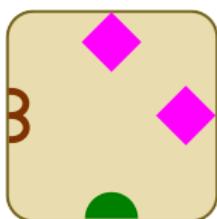
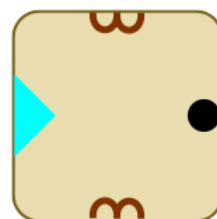
A	B	C	D	E
				





## Benjamin - 5.-6. klasse - 2022



### Opgave 12: Tænd lyset





Spillet "Tænd lyset" har 8 kontakter, der kan betjenes.

Der er ledninger, som går ud af disse kontakter, videre gennem nogle komponenter og til sidst ender i en elpære.

Kontakten  er slukket.

Kontakten  er tændt.

Udgangen fra komponenten  er kun tændt, når begge indgående ledninger er tændt.

Udgangen fra komponenten  er tændt, når lige præcis en af de indgående ledninger er tændt.

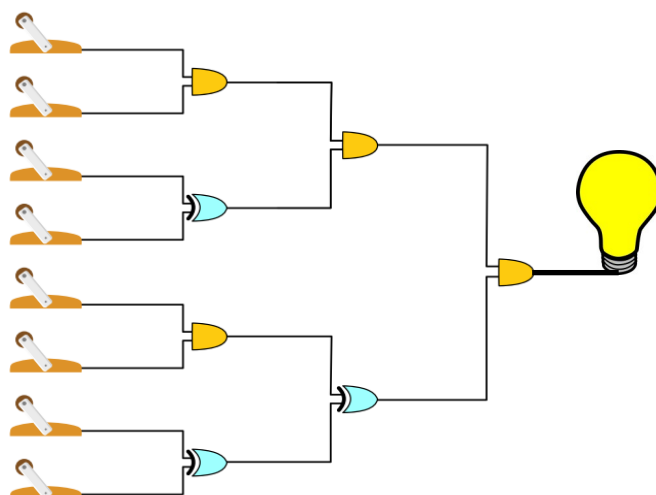

### Spørgsmål:

Hvilken løsning vil kunne tænde elpæren?

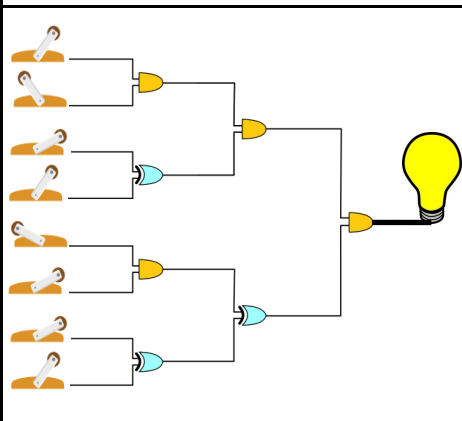
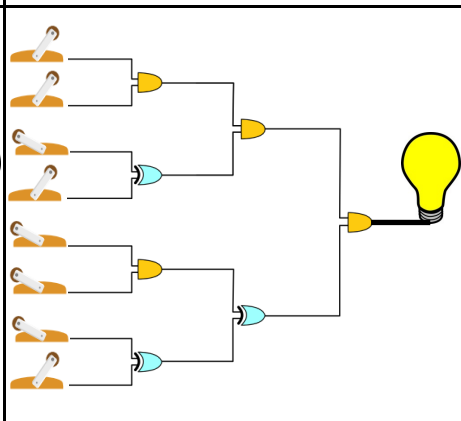
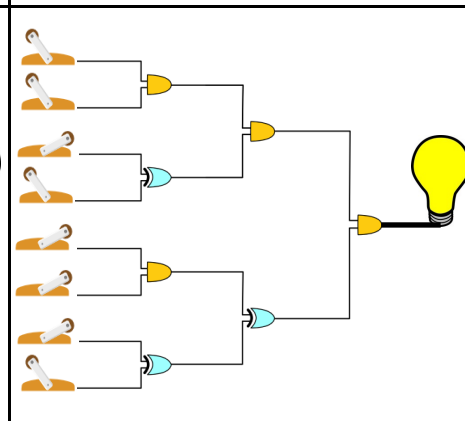
A	B	C
		





## Benjamin - 5.-6. klasse - 2022



### Opgave 13: Møtrikker og bolte



På metalfabrikken arbejder Bæveren ved samlebåndet for møtrikker og bolte.

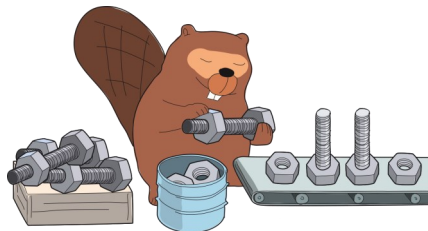

#### Bæverens arbejde:

Bæveren står i den ene ende af et langt transportbånd, hvor der kører en række møtrikker og bolte.

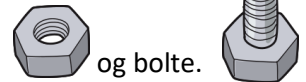



- Bæverens opgave er at tage både møtrikker og bolte op fra transportbåndet.
- Hvis bæveren tager en møtrik fra transportbåndet, så lægger bæveren møtrikken i spanden.
- Hvis bæveren tager en bolt fra transportbåndet, så tager bæveren også en møtrik fra spanden.
- Bæveren skruer møtrikken og bolten sammen og stiller den samlede del på kassen.

Bæverens arbejde kan gå galt på to forskellige måder:

1. Hvis bæveren tager en bolt fra transportbåndet, og der ikke er nogen møtrik i spanden.
2. Hvis der ikke er flere møtrikker eller bolte på transportbåndet, og der stadig er møtrikker i spanden.

#### Spørgsmål:

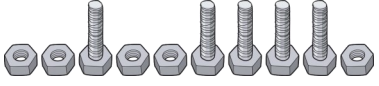
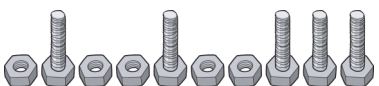
Hvilken række af møtrikker og bolte, når de opsamles fra venstre mod højre, vil ikke give problemer for bæverens arbejde?

<b>A</b>	
<b>B</b>	
<b>C</b>	
<b>D</b>	





## Benjamin - 5.-6. klasse - 2022



### Opgave 14: Kryptering med Cipher 8



Slovakiet

Ottekanten har enten tre eller fire bogstaver skrevet i hjørnerne.

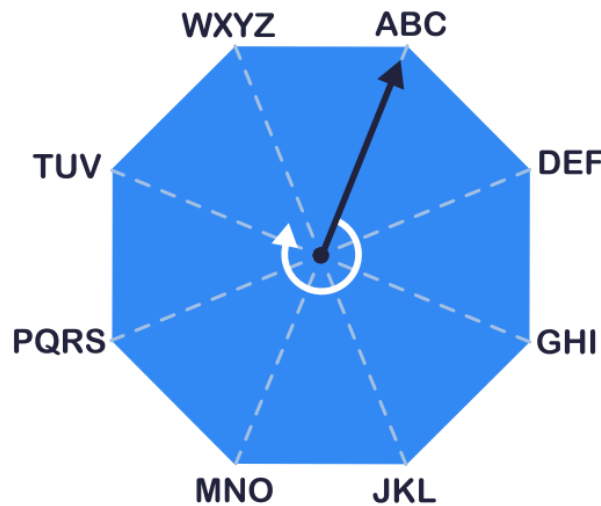

- En pil peger fra midten af ottekanten på en bogstavgruppe. Pilen kan rotere med uret.
- Ord kan krypteres ved hjælp af ottekanten og pilen.
- I begyndelsen af krypteringen af et nyt ord peger pilen altid på bogstaverne ABC.

Hvert bogstav i meddelelsen krypteres, så at:

1. Det første tal angiver, hvor mange hjørner på ottekanten, at pilen skal drejes fra dens nuværende plads
2. Det andet tal angiver placeringen af det krypterede bogstav i den bogstavgruppe, som pilen peger på.

Eksempel:

TREE er krypteret med sekvensen 61-73-42-02.

### Spørgsmål:

Hvad er krypteringen for WATER?

A	B	C	D
81-21-71-42-53	71-11-61-32-43	11-71-21-52-43	17-11-16-23-34





## Benjamin - 5.-6. klasse - 2022



### Opgave 15: Tæppevævning



Tyrkiet

Dagmar væver et firkantet tæppe med 6 rækker og 6 søjler.

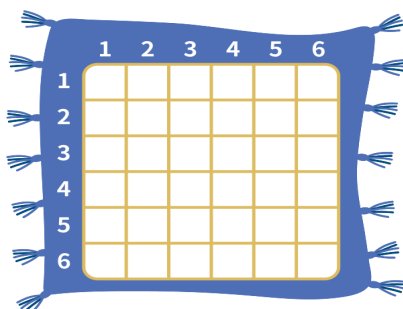

Dagmar sætter et symbol i hver firkant på tæppets gitter ud fra følgende spørgsmål:

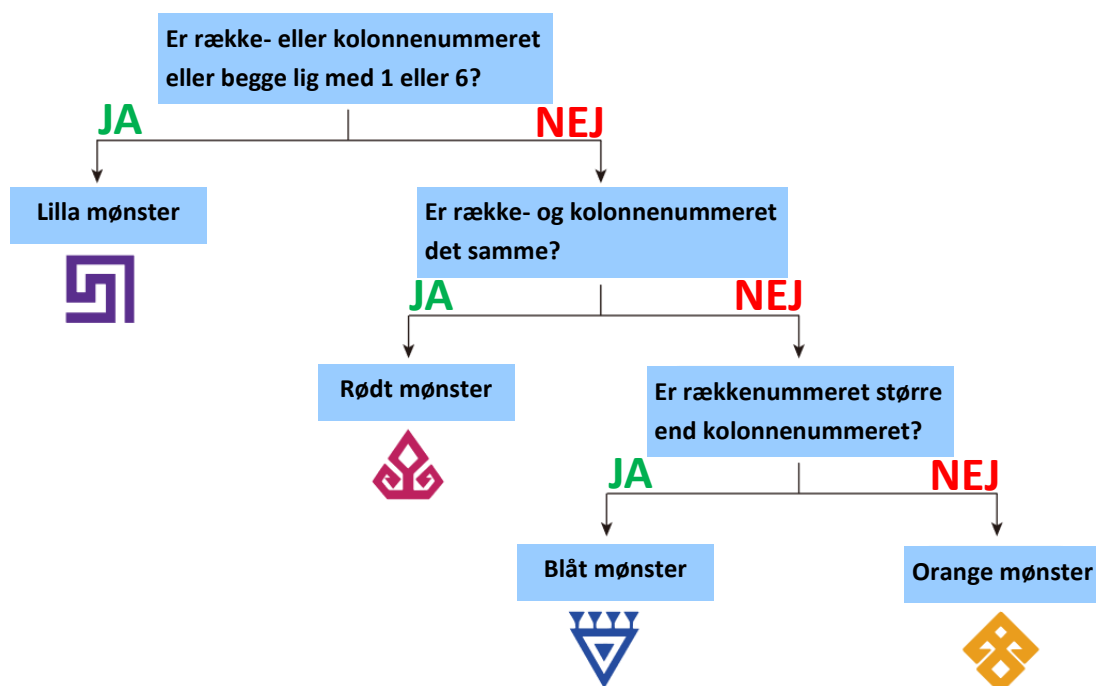

### Spørgsmål:

Hvordan ser det færdige tæppe ud efter denne metode?

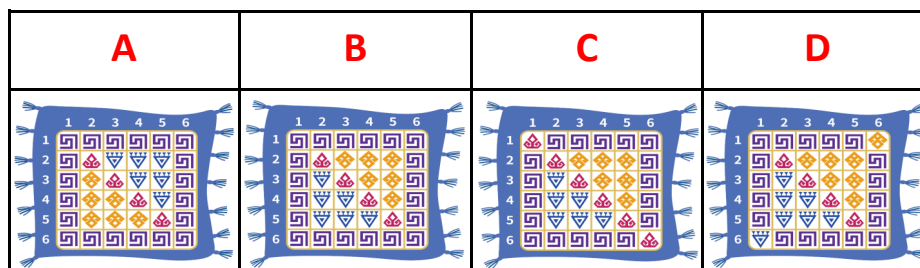



Benjamin - 5.-6. klasse - 2022

## FACITLISTE

Opgavenummer	Titel	Sværhedsgrad	Svarmulighed
1	Fodbolden	★	A
2	Gættespillet	★	B
3	Bøger på biblioteket	★	B
4	Skildpadden og haren	★	F
5	Bæveren på hotel	★	K
6	Mikado	★ ★	C
7	Hjertegrafik	★ ★	A
8	Hamburgere	★ ★	D
9	Broderimaskinen	★ ★	C
10	Sømandshalskæde	★ ★	D
11	Puslespil	★ ★ ★	C
12	Tænd lyset	★ ★ ★	B
13	Møtrikker og bolte	★ ★ ★	C
14	Kryptering med Cipher 8	★ ★ ★	B
15	Tæppevævning	★ ★ ★	B

Point pr. opgave		
Opgaver	Stjerner	Point
1-5	★ ☆ ☆	6
6-10	★ ★ ☆	9
11-15	★ ★ ★	12





**Navn:** \_\_\_\_\_ **Klasse:** \_\_\_\_\_

Opgave	Titel	Svar
1	Fodbolden	
2	Gættespillet	
3	Bøger på biblioteket	
4	Skildpadden og haren	
5	Bæveren på hotel	
6	Mikado	
7	Hjertegrafik	
8	Hamburgere	
9	Broderimaskinen	
10	Sømandshalskæde	
11	Puslespil	
12	Tænd lyset	
13	Møtrikker og bolte	
14	Kryptering med Ciper 8	
15	Tæppevævning	

